

Chapter 8

INDUCTION HOPPER

60L Induction Hopper

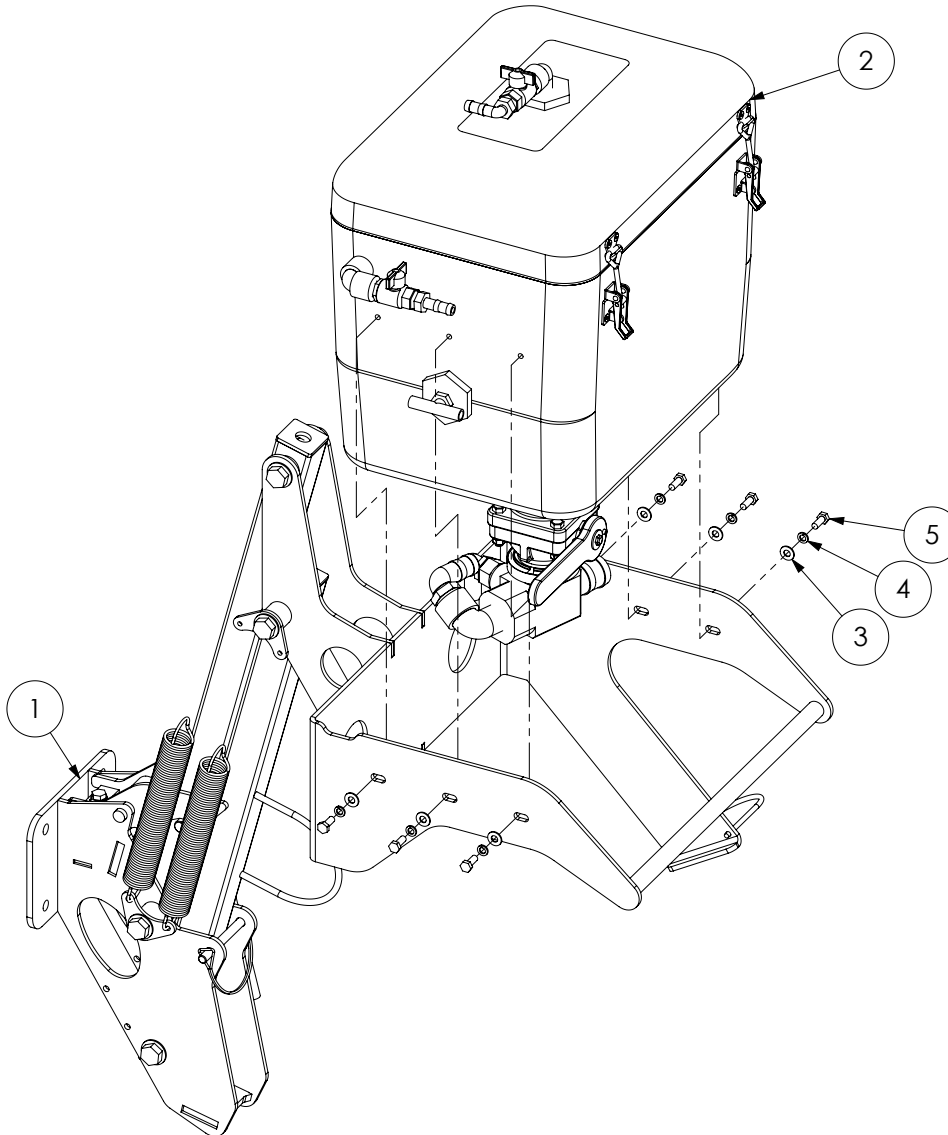

ITEM NO.	PART NUMBER	DESCRIPTION	QTY.
1	*	60L Induction Hopper Frame	1
2	*	60L Induction Hopper Tank Assembly	1
3	GA5003643	Washer 8mm HD	6
4	GA5004919	Washer 8mm Spring SS	6
5	GA5004085	Bolt M8 x 20 GR8.8 ZP	6

* Sub-assembly on following pages

60L Induction Hopper Frame

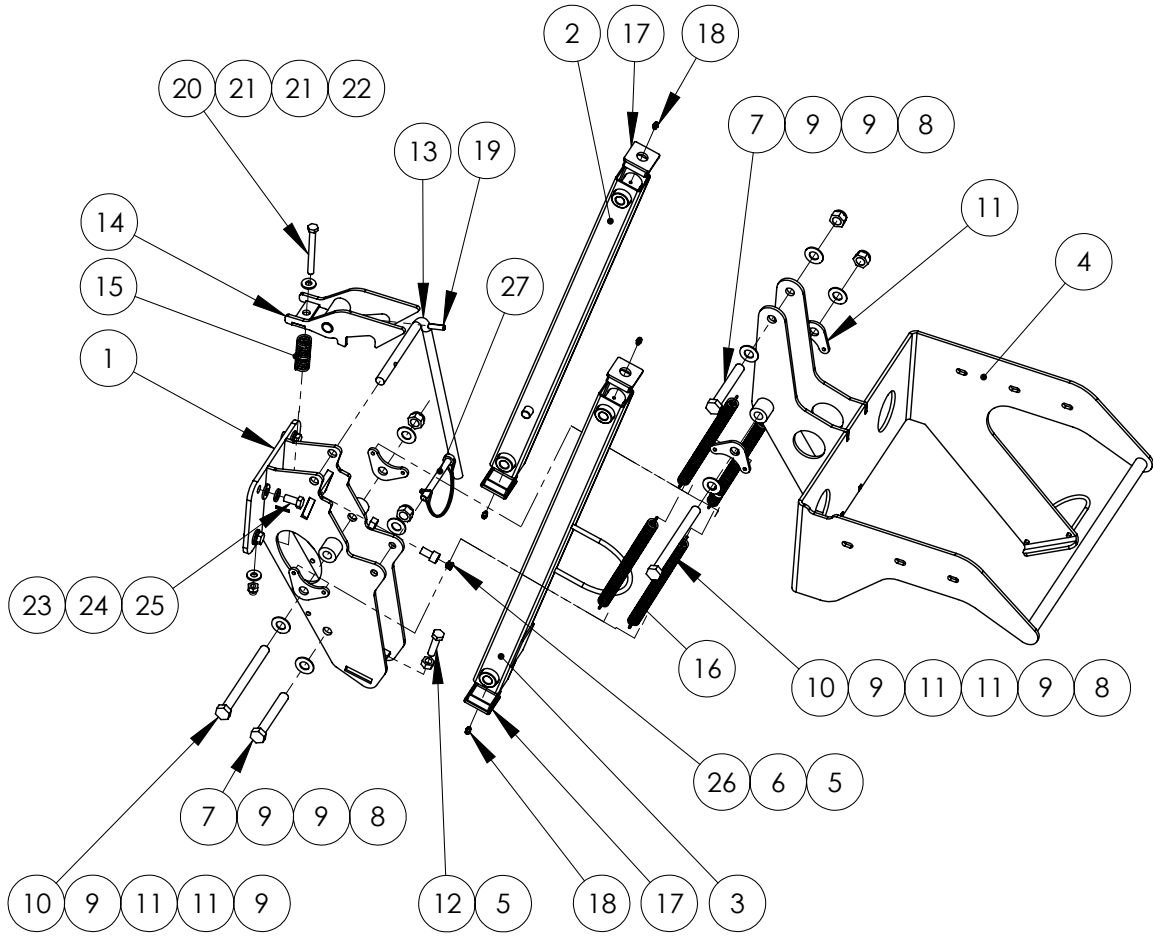

ITEM NO.	PART NUMBER	DESCRIPTION	QTY.
1	GA4653420	Induction Hopper Chassis Mount Advance	1
2	GA4653440	Induction Hopper Arm Upper Advance	1
3	GA4653445	Induction Hopper Arm Lower Advance	1
4	GA4656855	Induction Hopper tank support 60L suit EF range	1
5	GA5000559	Nut M12 Hex ZP	2
6	GA5050330	SHCS M12 x 20 ZP GR12.9	1
7	GA5000855	Bolt M16 x 110 GR8.8 ZP	2
8	GA5001029	Nut M16 Nyloc ZP	4
9	GA5001043	Washer 16mm Flat SS HD	8
10	GA5000879	Bolt M16 x 180 GR8.8 ZP	2
11	GA4522294	Mounting plate, Double induction hopper spring	4
12	GA5000327	Set Screw M12 x 45 GR8.8 ZP	1
13	GA4699435	Handle, Induction Hopper Latch Arm	1
14	GA4653490	Induction Hopper Latch Advance	1
15	GA5007329	Spring compression, 76.2mm x 25.4 x 3.15mm, gold	1
16	GA5007073	Spring, Tension, 38.2 OD x 284.3 long x 3.55mm	4
17	GA5003783	End cap, Insert, Black, Plastic, 50 x 50 mm	4

Continued over page

60L Induction Hopper Frame

ITEM NO.	PART NUMBER	DESCRIPTION	QTY.
18	GA5012203	Grease nipple, Short, 1/4" UNF	4
19	GA5075130	Roll pin M8 x 30mm coated	1
20	GA5006091	Bolt M10 x 100 GR8.8 ZP	1
21	GA5000117	Washer 10mm Flat SS HD	2
22	GA5000141	Nut M10 Nyloc ZP	1
23	GA5000577	Washer 12mm Flat SS HD	4
24	GA5000575	Washer 12mm Spring SS	4
25	GA5011229	Bolt M12 x 25 GR8.8 ZP	4
26	GA5052905	Insert, suit 12mm Hole, Black, plastic	1
27	GA5048380	Pin, 11mm OD shaft, Spring Steel wire loop lock, Yellow zinc	1

60L Induction Hopper Tank

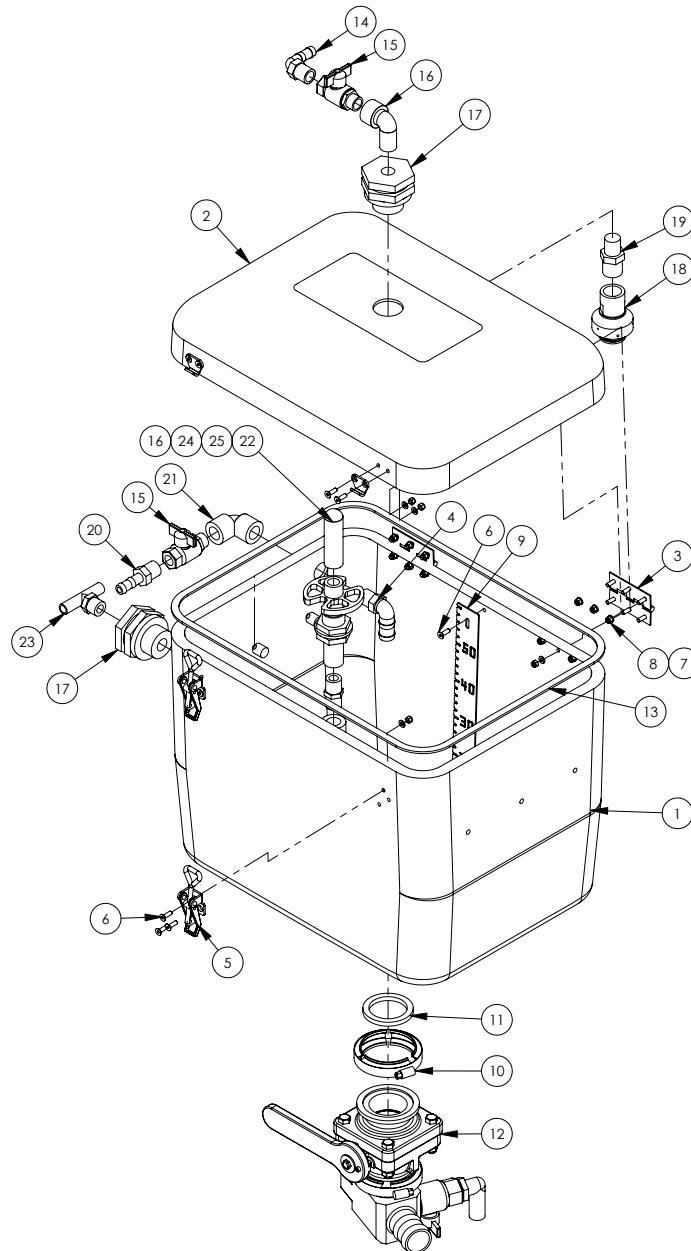

ITEM NO.	PART NUMBER	DESCRIPTION	QTY.
1	GA5071208	Tank, Induction Hopper, 60L with Flange to suit Banjo 220 Valve	1
2	GA5070045	Hopper lid - 07 Advance 65L	1
3	GA5006661	Hinge, Butt, 70 long x 50 wide x 1.5mm, SS	2
4	GA5077704	Hose barb, Elbow, 90 degree, 1/2" male thread x 3/4" hose	1
5	GA5007071	Latch, Adjustable, Induction Hopper Lid	2
6	GA5051230	CSCS M5 x 16 SS A2-70	23
7	GA5003983	Washer 5mm Flat SS	23
8	GA5003975	Nut M5 Nyloc SS	23
9	GA4522296	Level indicator, 60L induction hopper	1
10	FC220	2" Full Port Worm Screw Clamp	1

Continued over page

ITEM NO.	PART NUMBER	DESCRIPTION	QTY.
11	GA5076615	Seal, EPDM, Suit 2" flange fitting	1
12	*	60L Induction Hopper - Valve Bottom	1
13	GA5016473	Tape PM foam 6.4 x 18mm L/Density	1
14	GA5077708	Hose barb, Elbow, 90 degree, 1/2" male thread x 1/2" hose	1
15	GA5020615	Valve, Ball, 12mm male, female thread inlet, outlet, Butterfly handle, SS	2
16	GA5078133	Street elbow, 90 degree, 1/2" female thread x 1/2" male thread	2
17	GA5078156	Tank flange, 1/2" female threads	2
18	GA5077336	Nozzle, Tank rinsing, 3/4" BSPT female inlet	1
19	GA5078087	Reducing nipple, 3/4" male thread x 1/2" male thread	1
20	GA5077702	Hose barb, Straight, 1/2" male thread x 1/2" hose	1
21	GA5077652	Street elbow, 90 degree, 1/2" female thread	1
22	GA5077063	Nozzle, Drum & container rinsing	1
23	GA3500391	Tee, Threaded, 1/2" male x 1/2" hose	1
24	GA5077911	Nipple, Short, 1/2" male thread x 1/2" male thread	1
25	GA5077062	Valve, Drum & container rinsing nozzle	1

* Sub-assembly on following pages

60L Induction Hopper - Valve Bottom

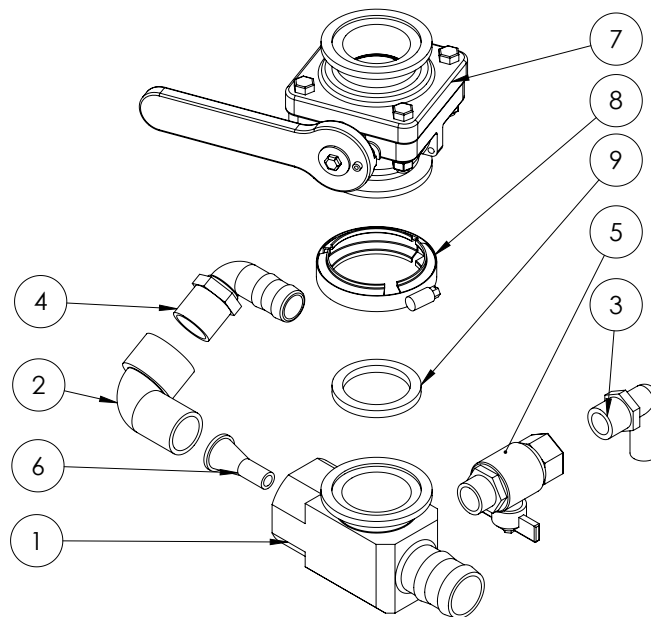

ITEM NO.	PART NUMBER	DESCRIPTION	QTY.
1	GA4552240	Hopper Bottom Venturi Housing with 2" Flange	1
2	GA5078137	Street elbow, 90 degree, 1" male x 1" female	1
3	GA5077717	Hose barb, Elbow, 90 degree, 3/4" male thread x 3/4" hose	1
4	GA5077723	Hose barb, Elbow, 90 degree, 1" male x 1" hose	1
5	GA5018315	Valve, Ball, 20mm male & female thread, Black Butterfly handle	1
6	L057A	Venturi, 9mm outlet, Suit induction hopper	1
7	GA5077908	Ball valve, 2" Full port, 4 Bolt Flanged, short	1
8	FC220	2" Full Port Worm Screw Clamp	1
9	GA5076615	Seal, EPDM, Suit 2" flange fitting	1

