

3PL, 450L, Work Ready

GA8701520 REV00

GA4907150 - PARTS MANUAL

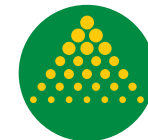

GOLDACRES



For further information about any of the products shown please visit - www.goldacres.com.au

© Goldacres Trading 2021
This publication and all designs are copyright.

No part, products or designs may be reproduced by any process except in accordance with the Copyright act 1968.

All information in this operator's manual is based on the latest product information available at the time of printing. The policy of Goldacres is one of continuous improvement and as such, Goldacres reserve the right to alter any specifications and designs without notice and without incurring any obligation regarding such changes.

No part of this manual may be reproduced without written permission from Goldacres. All photographs and technical information remain the property of Goldacres.

Goldacres Trading Pty Ltd
3 Morang Crescent
Mitchell Park Vic 3355
Ph: 03 5342 6399
Fax: 03 5342 6308



Contents	3
3PL, 450L, Work Ready, No Boom	4
Frame, 3PL, 450L	5
Frame & Pump	6
Pump, UDOR, ZETA 70 1C.	7
PTO.	8
Tank Assembly Drawing.	9
Suction Filter	11
Pressure Manifold	12
Hose Reel	13
Gunjet AA30	14
Plumbing	15
Goldacres Terms & Conditions of Sale & Warranty.	17



3PL, 450L, Work Ready, No Boom

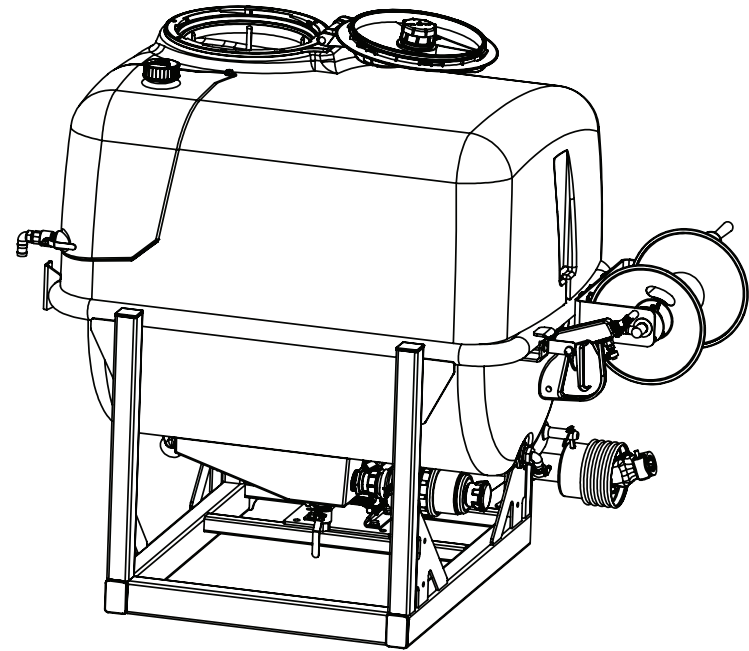
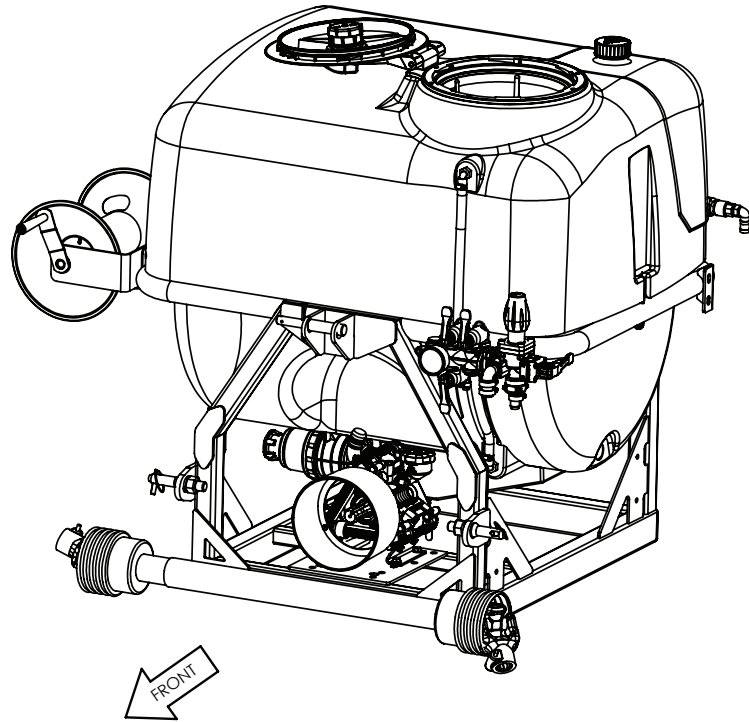

Frame, 3PL, 450L

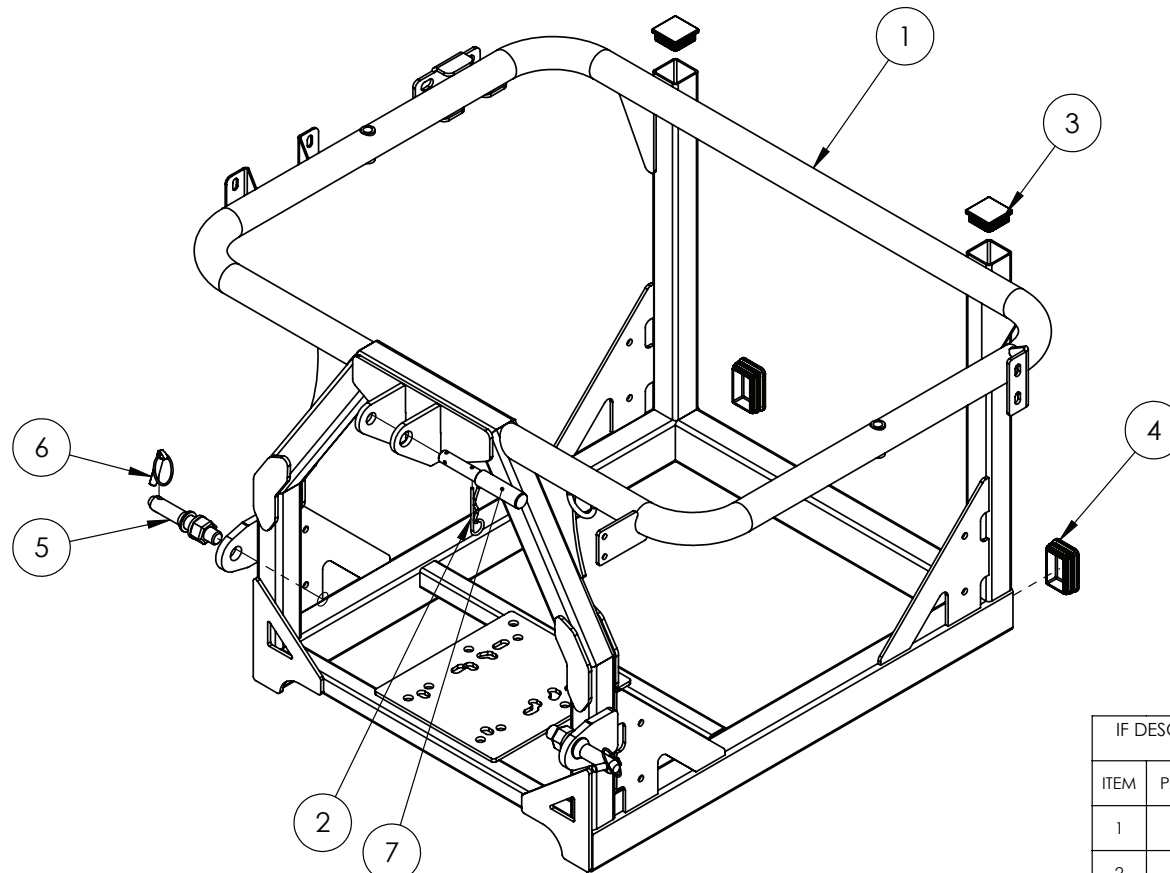

IF DESCRIPTION PREFIX IS ASSEMBLY DRAWING ONLY OR PRODUCTION DRAWING ONLY THE ITEM IS NOT FOR SALE

ITEM	PART NUMBER	DESCRIPTION	QTY
1	GA4660215	3 POINT LINKAGE SPRAYER FRAME 450L RETAIL READY 2014	1
2	GA5007197	CLIP R TYPE 4 mm Z/P S12	1
3	GA5024720	END CAP, PLASTIC, BLACK, INSERT, RHS. 50 X 50, 2.4 - 4.0mm WALL	2
4	GA5071885	END CAP, PLASTIC, BLACK, INSERT, RHS. 75 X 50, 2.5 - 4.5mm WALL	2
5	GA5010509	IMPLEMENT PIN, CAT 1	2
6	GA5010905	LINCH PIN, 7/16" OD X 45 LONG	2
7	GA5016789	TOP LINK PIN, DUAL CAT.	1
GA4908070		ASSEMBLY DRAWING ONLY, 3PL, 450L FRAME	REV 02





Frame & Pump

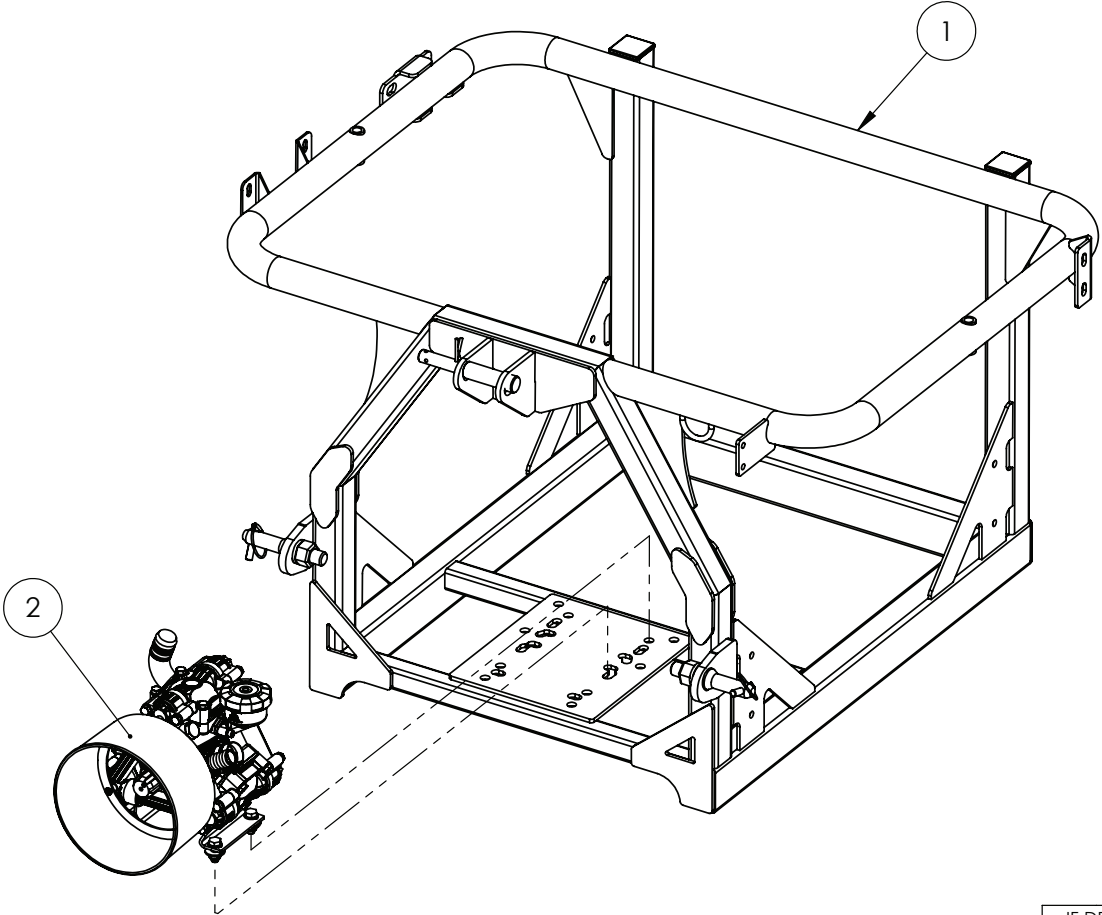

IF DESCRIPTION PREFIX IS ASSEMBLY DRAWING ONLY OR PRODUCTION DRAWING ONLY THE ITEM IS NOT FOR SALE			
ITEM	PART NUMBER	DESCRIPTION	QTY
1	GA4908070	ASSEMBLY DRAWING ONLY, 3PL, 450L FRAME	1
2	GA4908940	ASSEMBLY DRAWING ONLY, PUMP, ZETA 70 PTO	1
GA4907150-01		ASSEMBLY DRAWING ONLY, FRAME	REV 00

Pump, UDOR, ZETA 70 1C

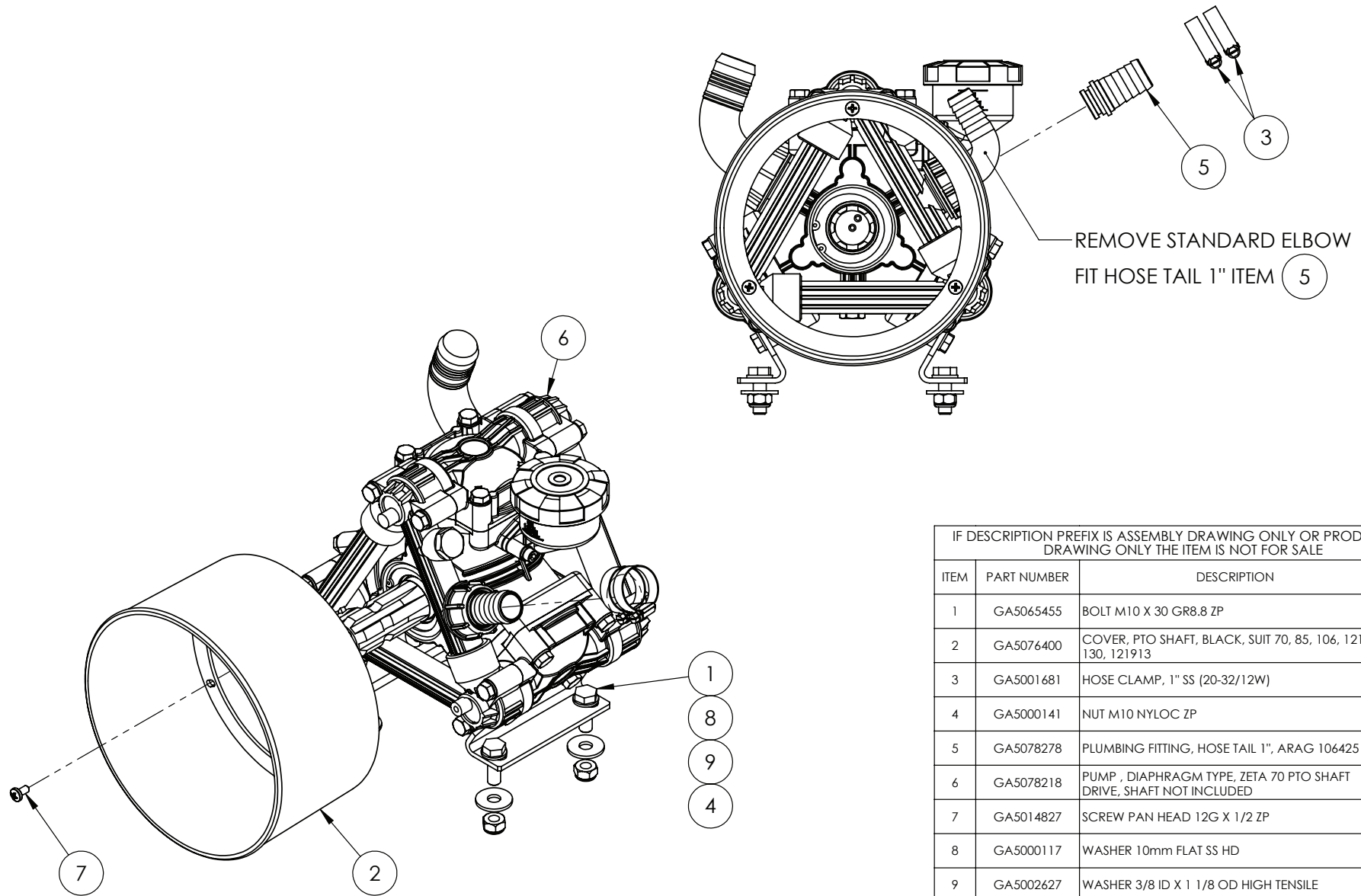

IF DESCRIPTION PREFIX IS ASSEMBLY DRAWING ONLY OR PRODUCTION DRAWING ONLY THE ITEM IS NOT FOR SALE			
ITEM	PART NUMBER	DESCRIPTION	QTY
1	GA5065455	BOLT M10 X 30 GR8.8 ZP	4
2	GA5076400	COVER, PTO SHAFT, BLACK, SUIT 70, 85, 106, 121, 130, 121913	1
3	GA5001681	HOSE CLAMP, 1" SS (20-32/12W)	2
4	GA5000141	NUT M10 NYLOC ZP	4
5	GA5078278	PLUMBING FITTING, HOSE TAIL 1", ARAG 106425	1
6	GA5078218	PUMP , DIAPHRAGM TYPE, ZETA 70 PTO SHAFT DRIVE, SHAFT NOT INCLUDED	1
7	GA5014827	SCREW PAN HEAD 12G X 1/2 ZP	3
8	GA5000117	WASHER 10mm FLAT SS HD	4
9	GA5002627	WASHER 3/8 ID X 1 1/8 OD HIGH TENSILE	4
GA4908940		ASSEMBLY DRAWING ONLY, PUMP, ZETA 70 PTO	REV 00



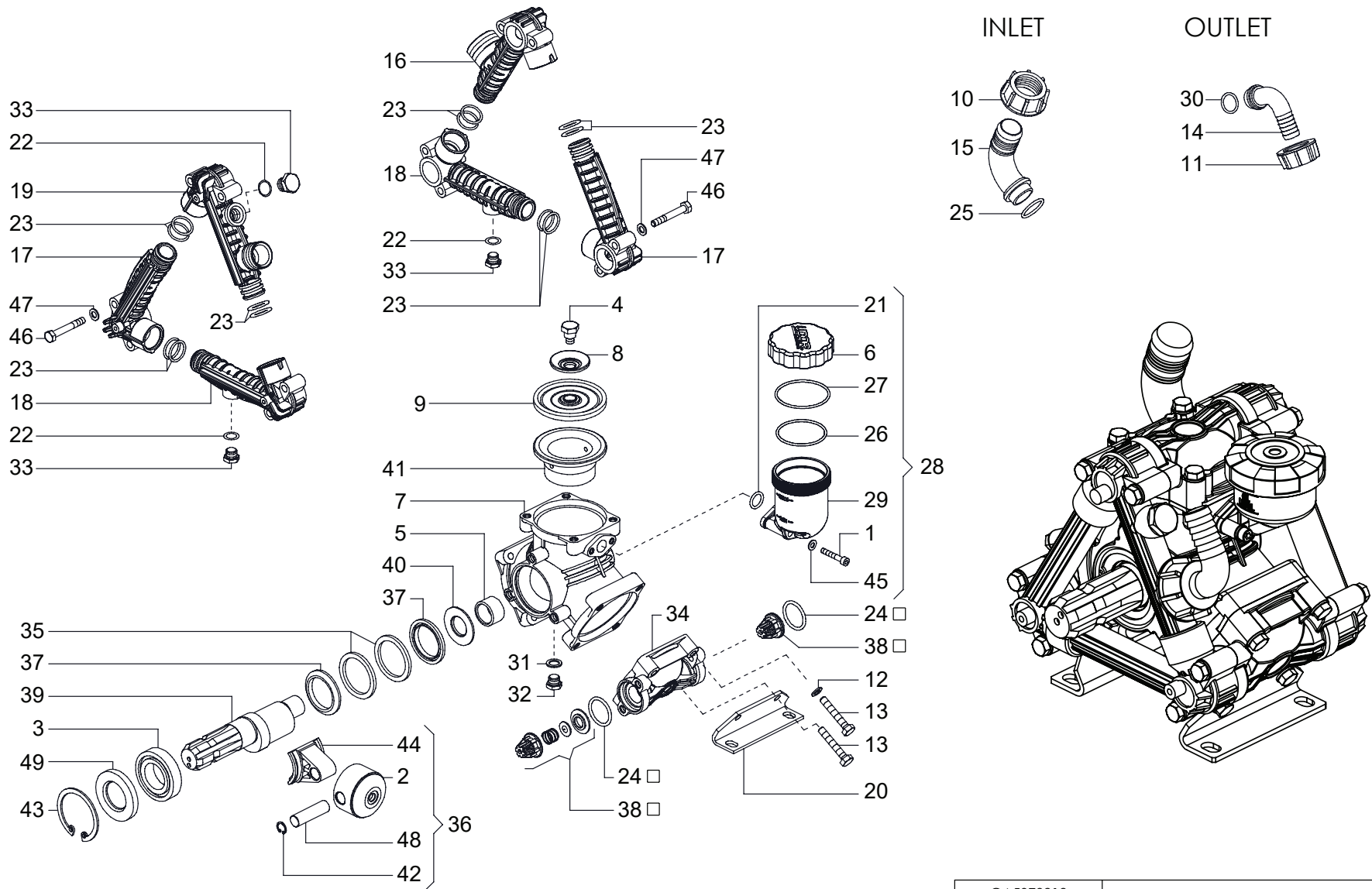



DIAPHRAGM PUMP, UDOR, ZETA 70 1C

ITEM	PART NUMBER	DESCRIPTION	ITEM	PART NUMBER	DESCRIPTION
1	GA5076570	ALLEN SCREW M6X30 UNI5931 DACROMET, 180531	26	110198	UDOR PART NUMBER, O RING, 110198
2	GA5078303	ALUMINIUM PLUNGER D60 "KAPPA 50/75..125", 120518	27	GA5076099	O RING, 58.42 X 2.62, 1101D1
3	GA5075732	BALL BEARING D35X62X14 6007, 021410	28	GA5077103	OIL RESERVOIR, ASSEMBLY, UDOR, 603313
4	GA5075660	BOLT, SUIT PUMP DIAPHRAGM, KAPPA / ZETA PUMPS, UDOR, 010204	29	GA5076381	OIL RESERVOIR, SUIT DIAPHRAGM PUMP, UDOR, 120328
5	GA5075624	BUSHING D25X32X20 HK25-20, 000602	30	GA5076060	O RING, 20.63 X 2.62, 110104
6	GA5075715	CAP, PUMP OIL RESERVOIR, UDOR, 020865	31	GA5075800	SEAL, RUBBER, 13 ID X 19 OD X 1.5, UDOR, 060549
7	GA5075726	CRANKCASE, ZETA 70, 020993	32	GA5076514	PLUG G1/4, 160367
8	GA5075757	DIAPHRAGM DISK, KAPPA 25/33/55/ ZETA 70, 030143	33	GA5078313	OIL PLUG, 3/8", BRASS, UDOR, 160364
9	GA5075997	DIAPHRAGM, PUMP PISTON, DIAMETER 90, SUIT KAPPA 55 & ZETA 70, DESMOPAN, UDOR, 090315	34	GA5076526	PUMP HEAD, ZETA 70, WITH FOOT, 605883
10	GA5075793	FLY NUT, 1 1/4, UDOR, 060432	35	GA5075602	RETAINER RING, ZETA 70 / KAPPA 40, 000106
11	GA5075794	FLY NUT, 1, UDOR, 060436	36	GA5077092	ROD ASSY "KAPPA 50/65" D60, 601528
12	GA5076443	WASHER D8,4X16X1,6 DACROMET, 140348	37	GA5075761	ROD SPACER "KAPPA 40/50/55/65", 030250
13	GA5076549	BOLT, M8 X 45mm, HEX SCREW UNI5737 DACROMET, UDOR, 180418	38	GA5077082	VALVE, CHECK, INLET / OUTLET, PUMP, WITH O RING, KAPPA, 600601, 6063Q5
14	GA5075744	HOSE BARB, ELBOW, 90 DEGREE, PUMP INLET/OUTLET, 20mm HOSE, UDOR, 025305	39	000274	UDOR PART NUMBER, SHAFT "ZETA 70 1C", 000274
15	GA5075684	HOSE BARB, ELBOW, 90 DEGREE, FLY NUT END X 32mm HOSE, UDOR, 020252	40	GA5075755	BEARING DISC "KAPPA 40/50/55/65", 030130
16	GA5076495	PUMP INLET, MANIFOLD SUCTION PIPE, G1-1/4 MALE, ZETA 70, 160131	41	GA5024650	SLEEVE, ZETA 70, UDOR, 020650
17	GA5076494	PUMP INLET, OUTLET MANIFOLD PIPE, ZETA 70, 160130	42	GA5076456	SNAP RING D15, 150615
18	GA5024655	MANIFOLD SECTION, CORNER WITH DRAIN, ZETA 70, UDOR, 160535	43	GA5024660	CIRCLIP, INPUT SHAFT, ZETA 70, UDOR, 150614
19	GA5076534	PUMP OUTLET, MANIFOLD PIPE, ZETA 70, G1 MALE, G3/8 FEMALE, 160534	44	GA5076474	CONNECTING ROD, ZETA 70, DELTA 40/50 151914, 151918
20	GA5076370	BASE MOUNT PLATE, ZETA 70, 120284	45	GA5076440	WASHER D6,4X12X1,6, 140307
21	GA5076072	O RING, 16.20 X 3.0, 110129	46	GA5076549	BOLT, M8 X 45mm, HEX SCREW UNI5737 DACROMET, UDOR, 180418
22	GA5078283	O-RING D14,00X2 (RIF.ORM0140-20), 1101F9	47	GA5076443	WASHER D8,4X16X1,6 DACROMET, 140348
23	GA5076070	O RING, 20.22 X 3.53, 110125	48	150207	UDOR PART NUMBER, CONNECTING ROD PIN, 150207
24	GA5076071	O RING, 31.43 X 3.53, 110127	49	GA5075635	OIL SEAL, 35 ID X 62 OD X 7, UDOR, 000758
25	GA5076074	O RING, 28.00 X 3.00, 110141			

GA5078218 	DIAPHRAGM PUMP, UDOR, ZETA 70 1C	REV
--	----------------------------------	-----

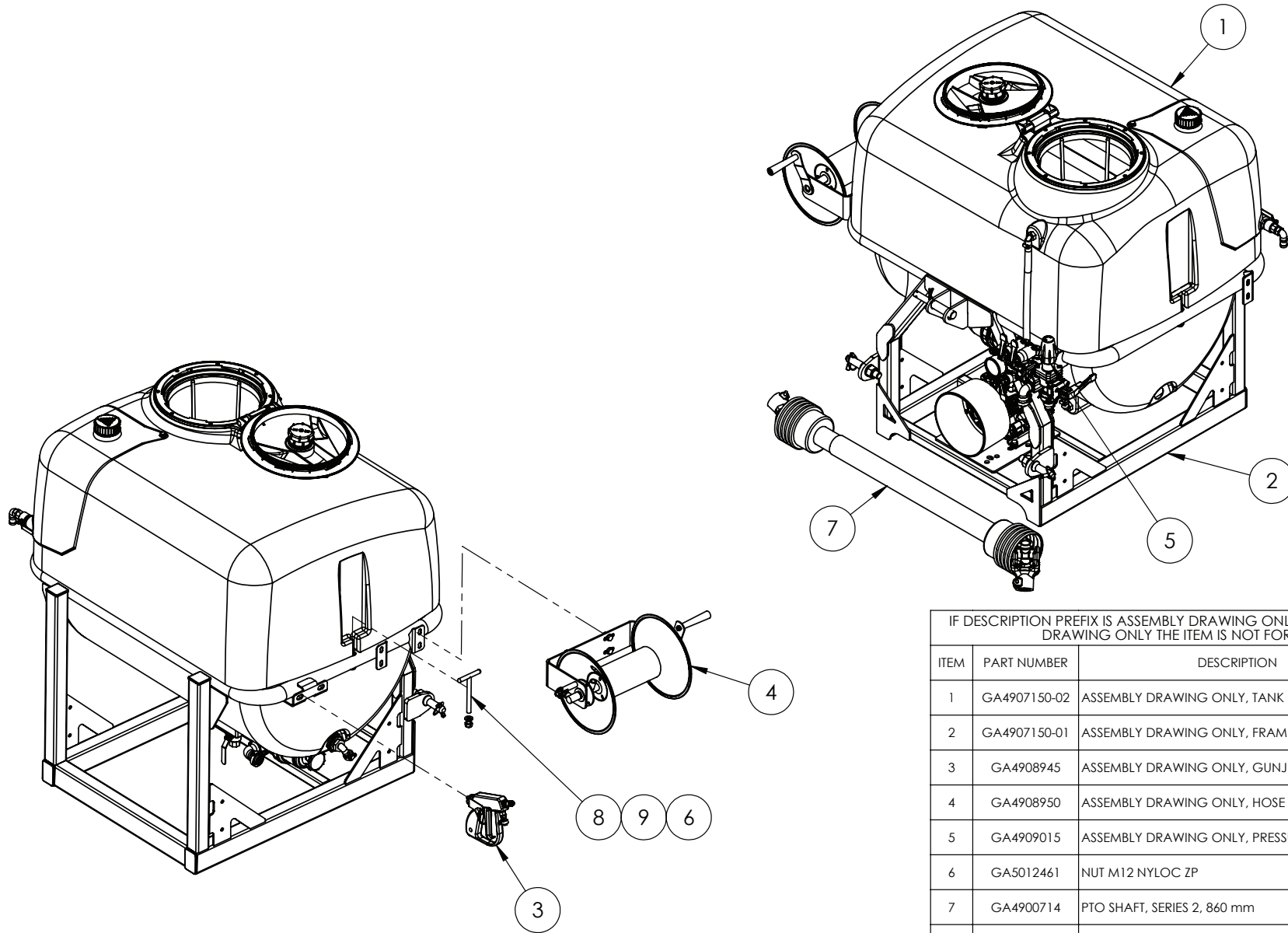

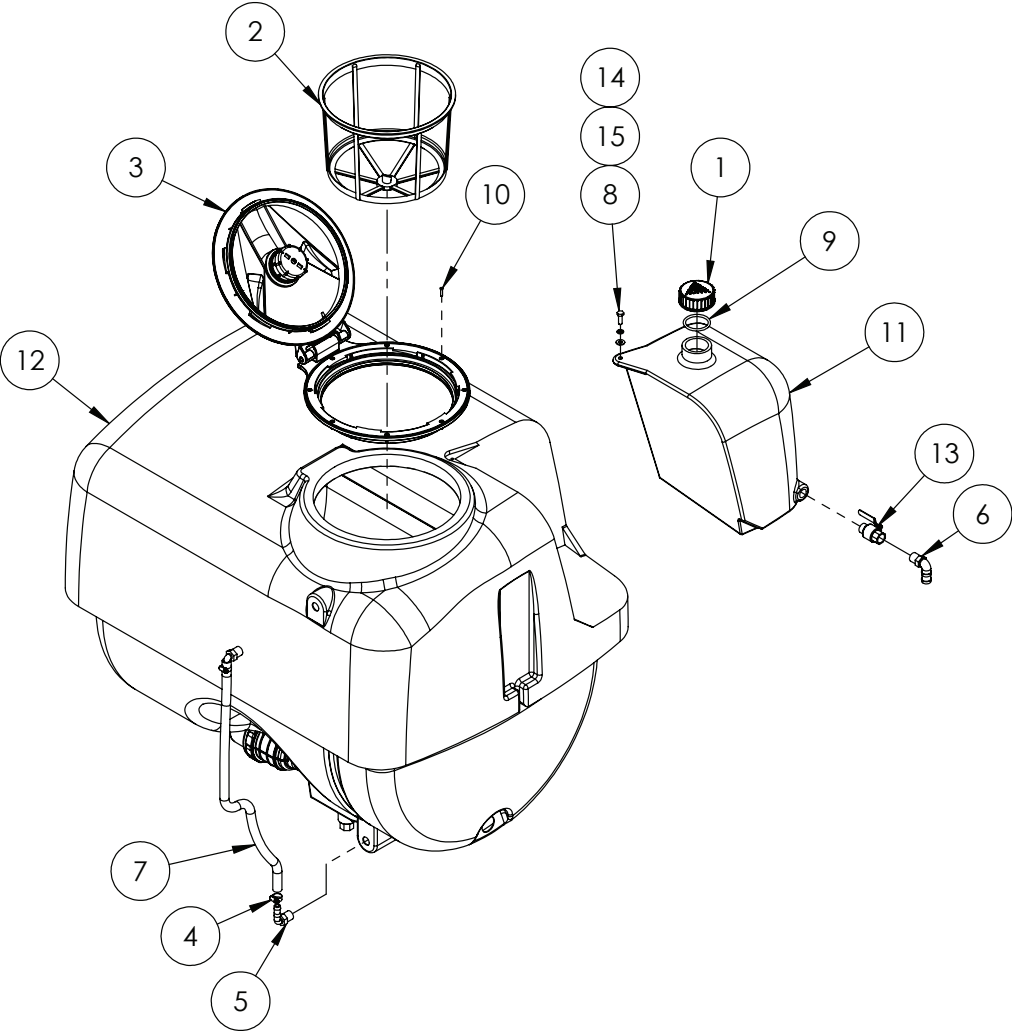

IF DESCRIPTION PREFIX IS ASSEMBLY DRAWING ONLY OR PRODUCTION DRAWING ONLY THE ITEM IS NOT FOR SALE			
ITEM	PART NUMBER	DESCRIPTION	QTY
1	GA4907150-02	ASSEMBLY DRAWING ONLY, TANK	1
2	GA4907150-01	ASSEMBLY DRAWING ONLY, FRAME	1
3	GA4908945	ASSEMBLY DRAWING ONLY, GUNJET AA30	1
4	GA4908950	ASSEMBLY DRAWING ONLY, HOSE REEL	1
5	GA4909015	ASSEMBLY DRAWING ONLY, PRESSURE MANIFOLD	1
6	GA5012461	NUT M12 NYLOC ZP	2
7	GA4900714	PTO SHAFT, SERIES 2, 860 mm	1
8	GA5071830	T BOLT, M12 130mm LONG 90mm WIDE	2
9	GA5000577	WASHER 12mm FLAT SS HD	2
GA4907150 GOLDACRES 3PL, 450L, WORK READY, NO BOOM			REV 06

Tank Assembly Drawing

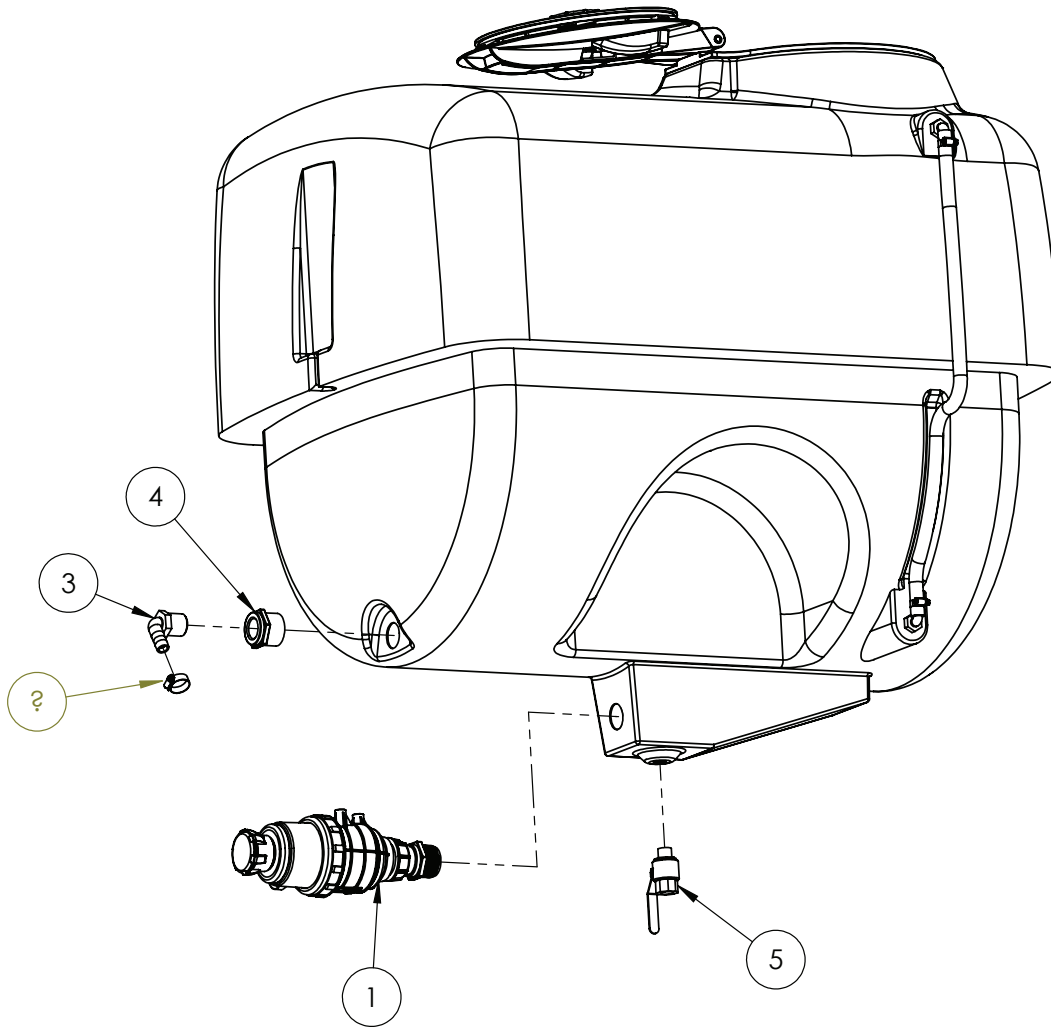

IF DESCRIPTION PREFIX IS ASSEMBLY DRAWING ONLY OR PRODUCTION DRAWING ONLY THE ITEM IS NOT FOR SALE			
ITEM	PART NUMBER	DESCRIPTION	QTY
1	GA5075400	CAP, TANK, PLASTIC, LID, M65.5X8 THREAD, GOLDACRES LOGO	1
2	GA5076714	FILTER, BASKET TYPE, DIAMETER 305 X 245 DEEP, SUIT MAIN SPRAY TANK	1
3	GA5078336	HINGED LID D.355 FLAT SURFACE	1
4	GA5000469	HOSE CLAMP, 1/2" SS 12-20/9W3	2
5	GA5077708	HOSE BARB, ELBOW, 90 DEGREE, 1/2 MALE THREAD X 1/2 HOSE, BANJO, HB050-90	2
6	GA5077704	HOSE BARB, ELBOW, 90 DEGREE, 1/2 MALE THREAD X 3/4 HOSE, BANJO	1
7	GA2000210	HOSE, 12mm, CLEAR, WIRE REINFORCED	0.75
8	GA5004711	M8X25 SET SCREW	1
9	GA5009187	O RING, 60 OD, 50 ID X 5mm, SUITS EXACTA TANK CAP	1
10	GA5069815	SCREW CSK PHILLIPS M4 X 20 ZP	8
11	GA5071275	TANK, HANDWASH 3 POINT LINKAGE 2014	1
12	GA5071255	TANK, 450L 3 POINT LINKAGE 2014, WITH LID, BARE	1
13	GA5020620	VALVE, BALL, 12mm, 1/2" MALE, FEMALE, LEVER HANDLE, BRASS	1
14	GA5003643	WASHER 8mm FLAT SS HD	1
15	GA5004919	WASHER 8mm SPRING SS	1
GA4907150-02		ASSEMBLY DRAWING ONLY, TANK, 3PL, 450L	REV 00



IF DESCRIPTION PREFIX IS ASSEMBLY DRAWING ONLY OR PRODUCTION DRAWING ONLY THE ITEM IS NOT FOR SALE			
ITEM	PART NUMBER	DESCRIPTION	QTY
1	GA4908985	ASSEMBLY DRAWING ONLY, SUCTION FILTER	1
2	GA5000999	HOSE CLAMP, 3/4" SS (16-27/12W)	1
3	GA5077719	HOSE BARB, ELBOW, 90 DEGREE, 1 MALE THREAD X 3/4 HOSE, BANJO	1
4	GA5078018	REDUCING BUSH, 1 1/2 MALE THREAD X 1 FEMALE THREAD, BANJO	1
5	GA5018317	VALVE, BALL, 20mm, 3/4" MALE, FEMALE, LEVER HANDLE, BRASS	1
GA4907150-02  GOLDACRES			ASSEMBLY DRAWING ONLY, TANK, 3PL, 450L REV 00

Suction Filter

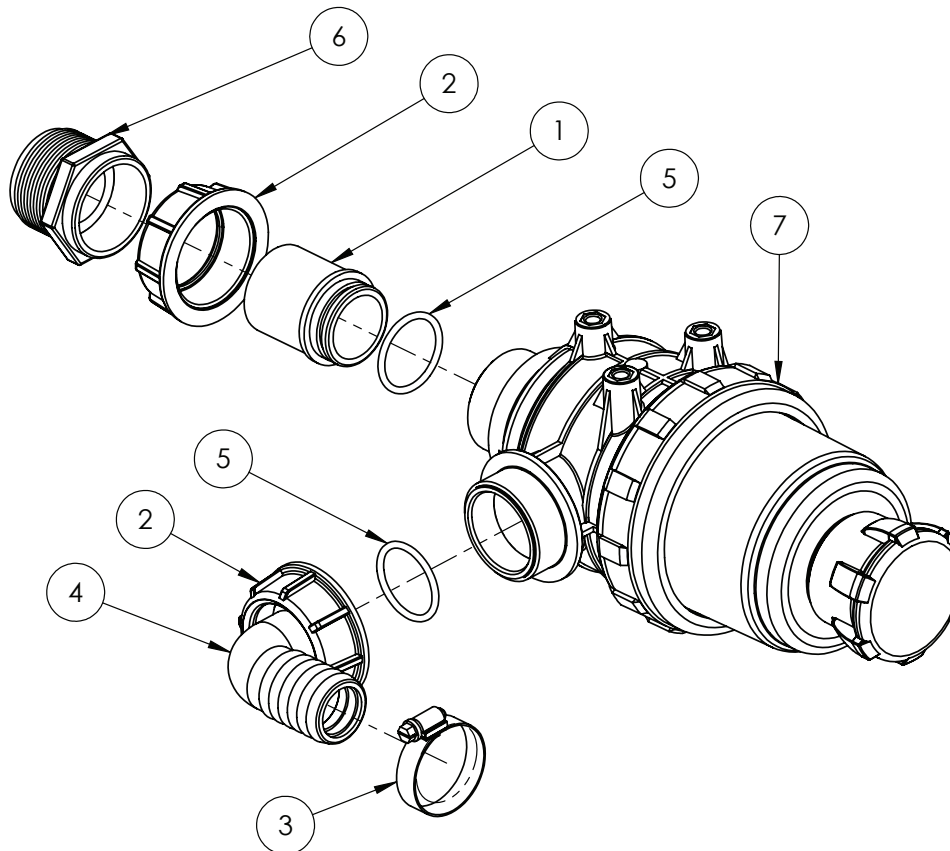

IF DESCRIPTION PREFIX IS ASSEMBLY DRAWING ONLY OR PRODUCTION DRAWING ONLY THE ITEM IS NOT FOR SALE			
ITEM	PART NUMBER	DESCRIPTION	QTY
1	GA5076712	COUPLING 1 1/4M FOR FLY NUT 1 1/2"	1
2	GA5076604	FLY NUT, 1 1/2"; ARAG, 2002060	2
3	GA5002783	HOSE CLAMP, 1 1/4, SS (30-45/13W)	1
4	GA5076259	HOSE BARB, ELBOW, 90 DEGREE, 1 1/2 FLY NUT END X 32 mm HOSE, ARAG	1
5	GA5077679	O RING, 30 X 3 mm, G10061	2
6	GA5078019	REDUCING BUSH, 1 1/2 MALE THREAD X 1 1/4 FEMALE THREAD, BANJO	1
7	GA5076758	SUCTION FILTER, 1 1/2, WITH SHUT OFF VALVE, 50 MESH, 3142463	1
GA4908985		ASSEMBLY DRAWING ONLY, SUCTION FILTER	REV 00



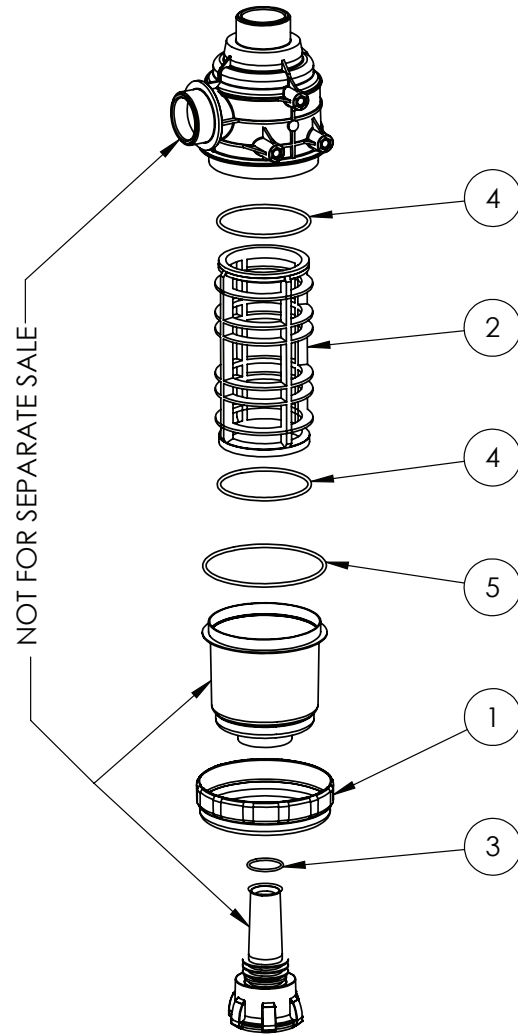

IF DESCRIPTION PREFIX IS ASSEMBLY DRAWING ONLY OR PRODUCTION DRAWING ONLY THE ITEM IS NOT FOR SALE			
ITEM	PART NUMBER	DESCRIPTION	QTY
1	GA5076750	314 SUCTION FILTER NUT, 314000.040	1
2	GA5076755	FILTER SCREEN, 50 MESH, DIA 79 X 167, 3142003.030	1
3	GA5077012	O RING, 31.0 X 2.5, 462300.230	1
4	GA5076760	O RING, 71.1 X 2.6, ARAG, 314300.060	2
5	GA5076751	O RING, 91.44 X 5.34, EPDM, 314000.050	1
GA5076758		SUCTION FILTER, 1 1/2, WITH SHUT OFF VALVE, 50 MESH, 3142463	REV 00

Pressure Manifold

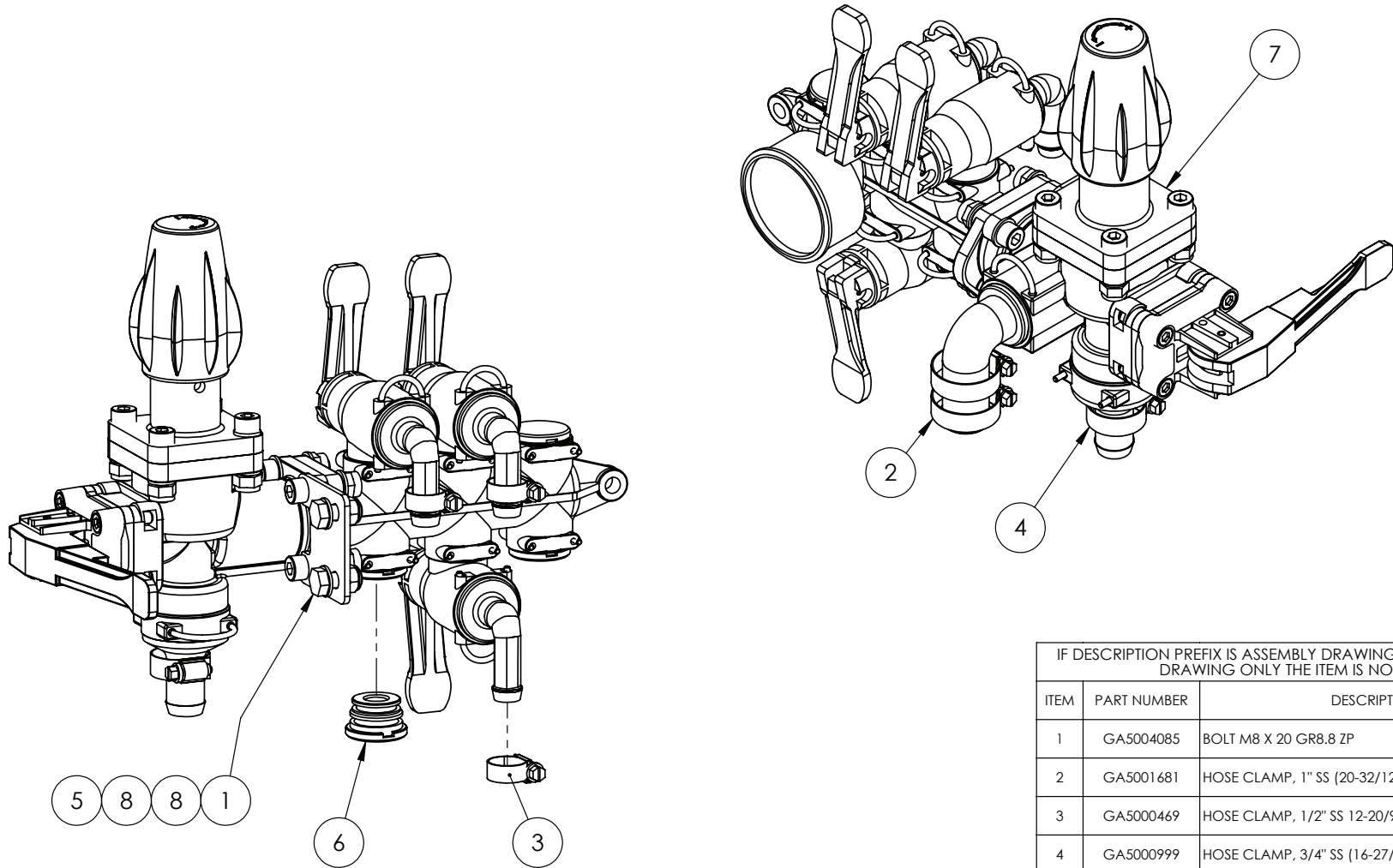

IF DESCRIPTION PREFIX IS ASSEMBLY DRAWING ONLY OR PRODUCTION DRAWING ONLY THE ITEM IS NOT FOR SALE

ITEM	PART NUMBER	DESCRIPTION	QTY
1	GA5004085	BOLT M8 X 20 GR8.8 ZP	2
2	GA5001681	HOSE CLAMP, 1" SS (20-32/12W)	2
3	GA5000469	HOSE CLAMP, 1/2" SS 12-20/9W3	3
4	GA5000999	HOSE CLAMP, 3/4" SS (16-27/12W)	1
5	GA5052590	NUT M8 NYLOC SS	2
6	GA2000058	PLUMBING FITTING, PLUG, GEOLINE	1
7	GA2000051	PRESSURE CONTROL VALVE, MANUAL, CONSTANT, 4 WAY, GEOLINE	1
8	GA5003643	WASHER 8mm FLAT SS HD	4
GA4909015		ASSEMBLY DRAWING ONLY, PRESSURE MANIFOLD	REV 00



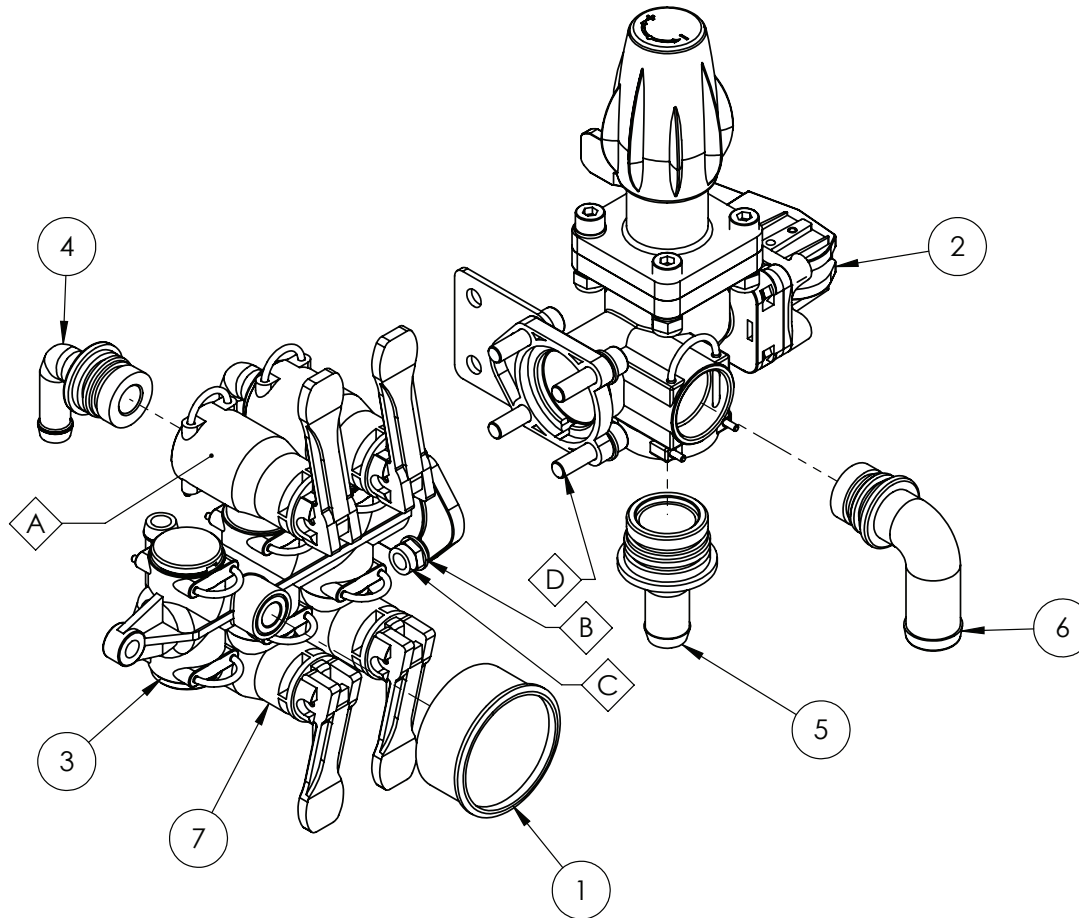

REPLACEMENT PARTS			
ITEM	PART NUMBER	DESCRIPTION	QTY
A	GA2000087	MODULAR SECTION VALVE, GEOLINE, SUITS GEOLINE MANIFOLD GA2000086 AND GA2000051	4
B	GA5003643	WASHER 8mm FLAT SS HD	6
C	GA5004917	NUT M8 NYLOC ZP	4
D	GA5070765	SHCS M8 X 30 GR12.9 ZP	4

IF DESCRIPTION PREFIX IS ASSEMBLY DRAWING ONLY OR PRODUCTION DRAWING ONLY THE ITEM IS NOT FOR SALE			
ITEM	PART NUMBER	DESCRIPTION	QTY
1	GA2000075	GAUGE PRESSURE, REAR MOUNT, 25 BAR, 1/4", COLOURED SCALE, GEOLINE, 8302200.	1
2	GA2000085	MAIN MANUAL CONTROL VALVE, ADJUSTABLE PRESURE RELIEF, GEOLINE	1
3	GA2000086	PLUMBING MANIFOLD, 4-6 SECTIONS, GEOLINE	1
4	GA2000056	PLUMBING FITTING, HOSE BARB 13mm, ELBOW, WITH ORING, OUTLET, GEOLINE	4
5	GA2000054	PLUMBING FITTING, HOSE BARB 19mm, WITH ORING, BYPASS, GEOLINE	1
6	GA2000060	PLUMBING FITTING, HOSE BARB 25mm, ELBOW, WITH ORING,	1
7	GA2000087	MODULAR SECTION VALVE, GEOLINE, SUITS GEOLINE MANIFOLD GA2000086 AND GA2000051	4
GA2000051		PRESSURE CONTROL VALVE, MANUAL, CONSTANT, 4 WAY, GEOLINE	REV 00

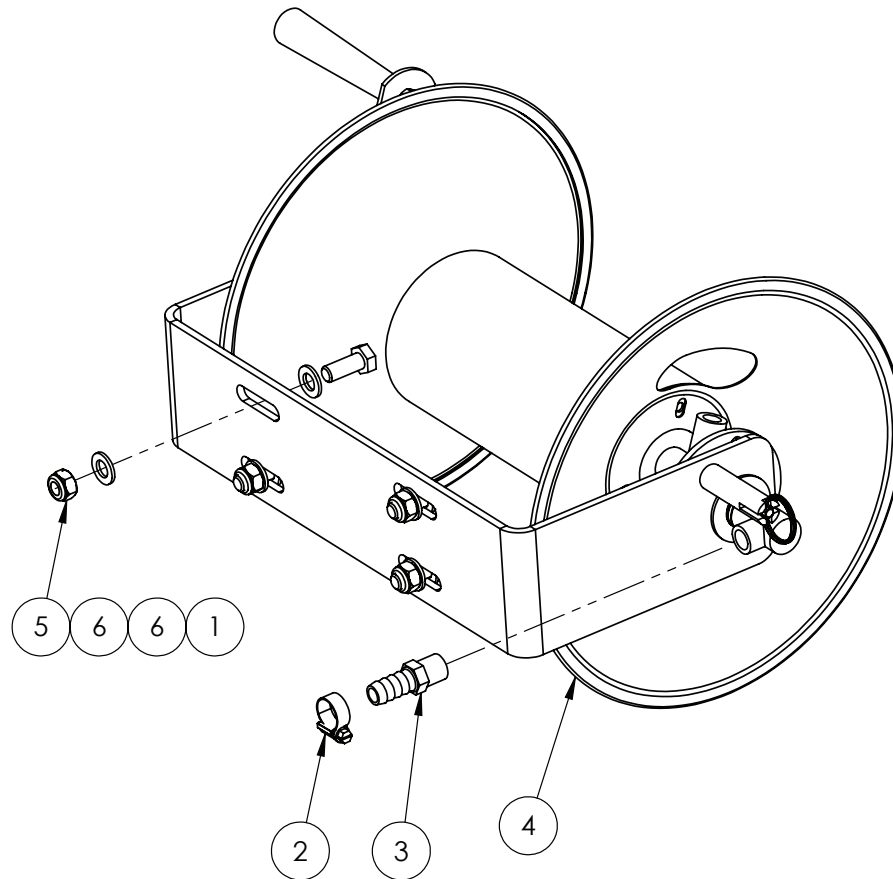

IF DESCRIPTION PREFIX IS ASSEMBLY DRAWING ONLY OR PRODUCTION DRAWING ONLY THE ITEM IS NOT FOR SALE			
ITEM	PART NUMBER	DESCRIPTION	QTY
1	GA5006161	BOLT M10 X 25 GR8.8 ZP	4
2	GA5000469	HOSE CLAMP, 1/2" SS 12-20/9W3	1
3	GA5021070	HOSE BARB, STRAIGHT, 3/8 BSP MALE X 1/2 HOSE, BRASS	1
4	GA5066080	HOSE REEL, 30m 3/8" HOSE, MANUAL REWIND	1
5	GA5000141	NUT M10 NYLOC ZP	4
6	GA5000117	WASHER 10mm FLAT SS HD	8
GA4908950 			REV 00



Gunjet AA30

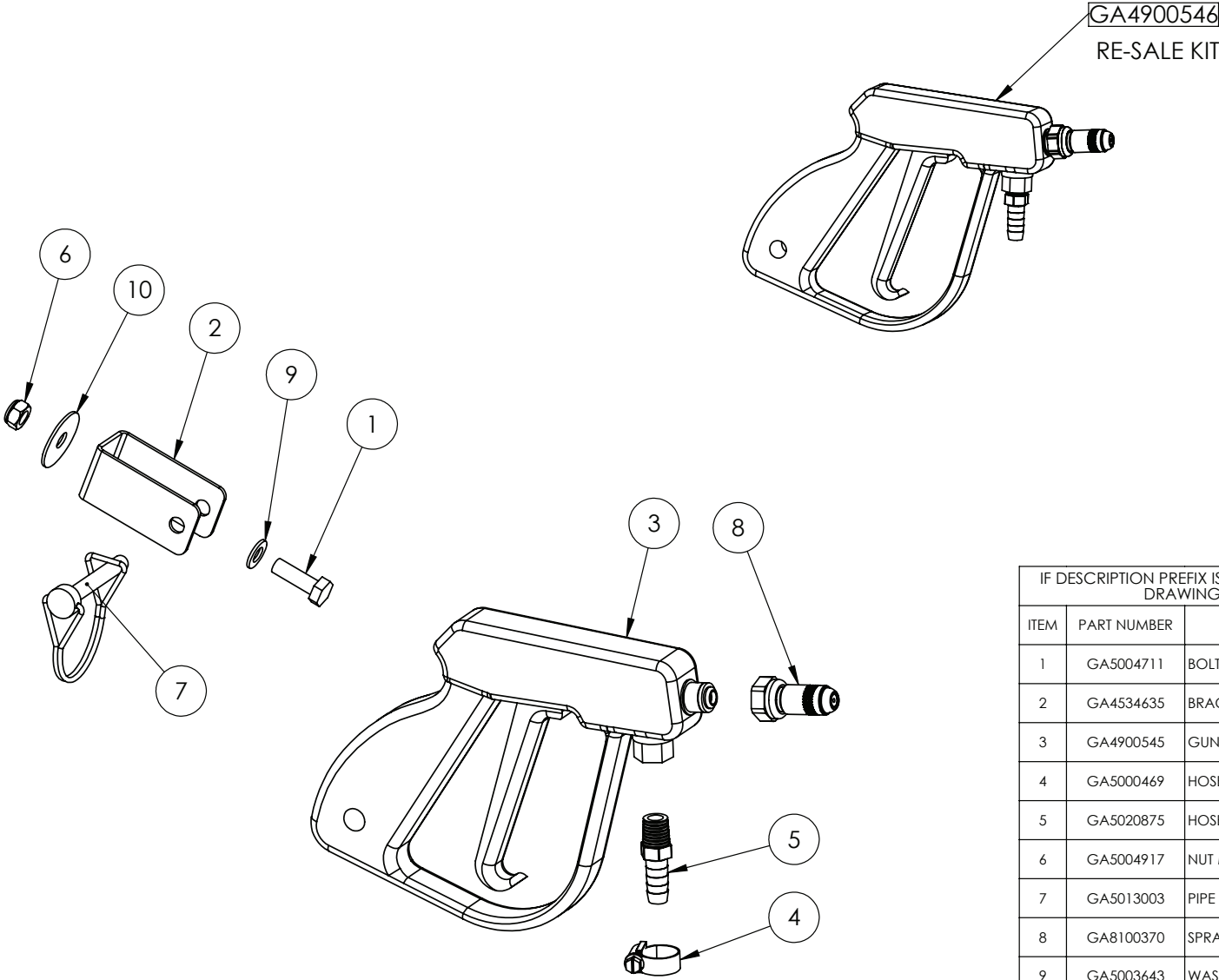

IF DESCRIPTION PREFIX IS ASSEMBLY DRAWING ONLY OR PRODUCTION DRAWING ONLY THE ITEM IS NOT FOR SALE			
ITEM	PART NUMBER	DESCRIPTION	QTY
1	GA5004711	BOLT M8 X 25 GR8.8 ZP	1
2	GA4534635	BRACKET, GUN JET, HOLDER SUPPORT	1
3	GA4900545	GUNJET AA30	1
4	GA5000469	HOSE CLAMP, 1/2" SS 12-20/9W3	1
5	GA5020875	HOSE BARB, 1/4 MALE THREAD X 1/2 BARB, BRASS	1
6	GA5004917	NUT M8 NYLOC ZP	1
7	GA5013003	PIPE LINCH PIN, 8 OD X 60 LONG	1
8	GA8100370	SPRAY TIP, ADJUSTABLE CONEJET, BRASS, 18, TEEJET	1
9	GA5003643	WASHER 8mm FLAT SS HD	1
10	GA5003645	WASHER FLAT SS 5-16 X 1 1-4	1
GA4908945 GOLDACRES			REV 00
ASSEMBLY DRAWING ONLY, GUNJET AA30			

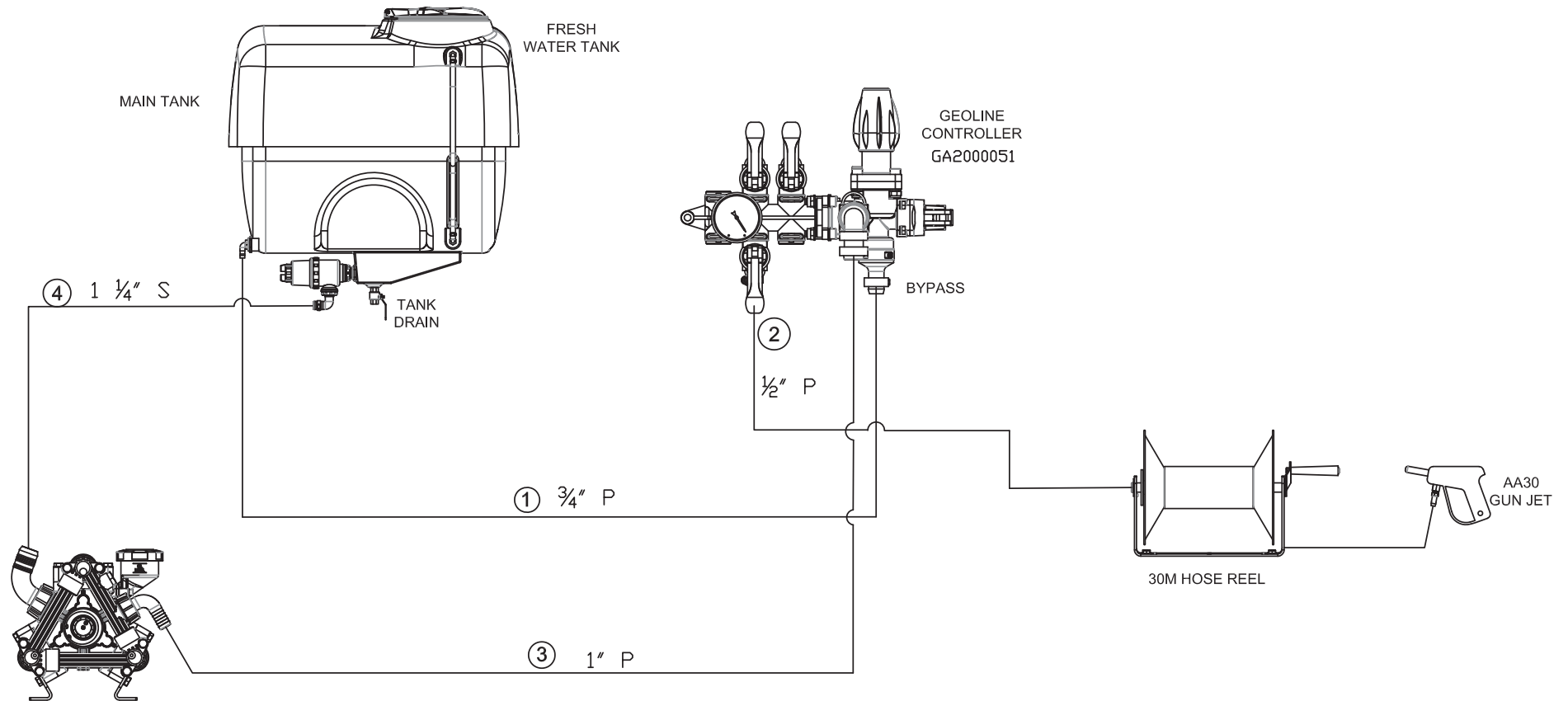

GA7500066 	3PL 450L WORK READY NO BOOM GA4907150 PLUMBING SCHEMATIC	REV 00
---------------	---	-----------



GA4907150 DECALS

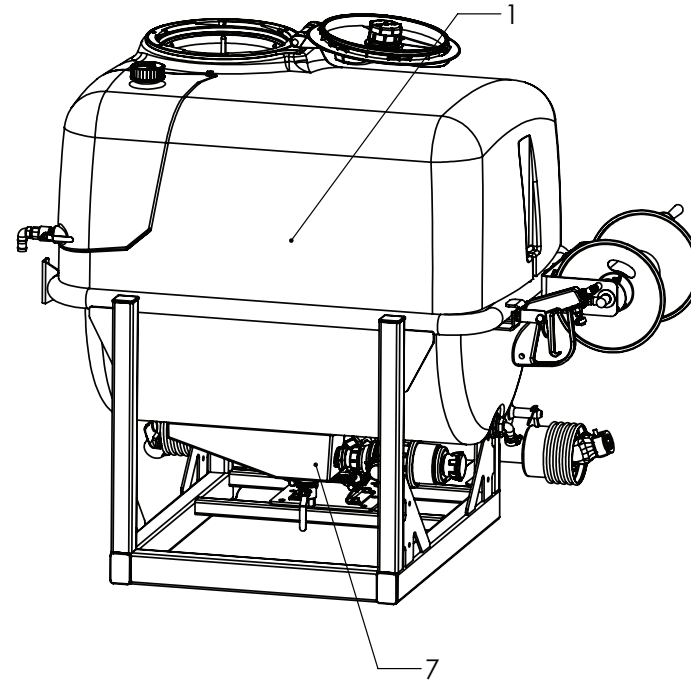
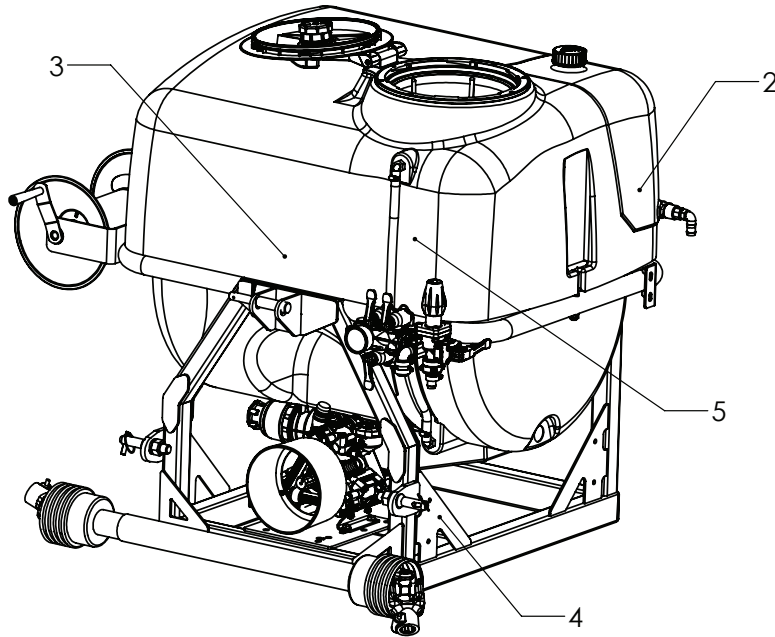
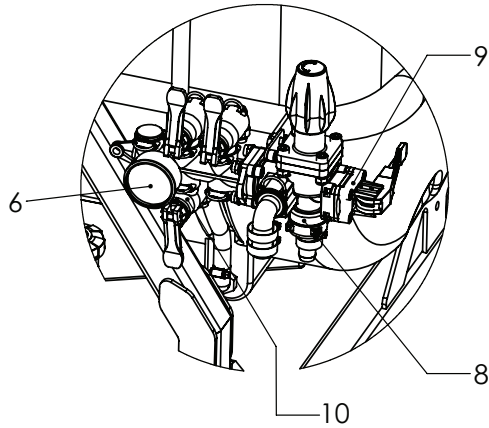

GA8701334 - DECAL, 3PL, 450L, WORK READY, NO BOOM

ITEM	PART NUMBER / DESCRIPTION
1	GA8700167 - TANK DECAL
2	GA8700140 - HAND WASH ONLY
3	GA8700172 - LARGE WARNING DECAL
4	GA5014955 - I.D. PLATE, STICK ON
5	GA8700310 - SIGHT TUBE, 450L
6	GA8700466 - MANIFOLD PRESSURE
7	GA8700483 - DRAIN ONLY
8	GA8700467 - BY PASS
9	GA8700470 - DUMP VALVE
10	GA8700469 - HOSE REEL

GA4907150



3PL, 450L, WORK READY, NO BOOM

REV
06

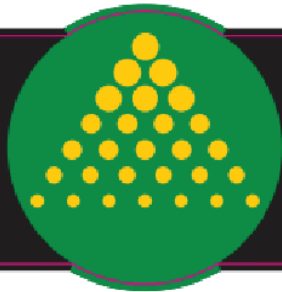

GOLDACRES

LINKAGE 450

3PL

BY PASS BOOM PROBE HOSE REEL BOOM DUMP VALVE

WARNING
P.T.O. SHAFT MAY NEED TO BE ALTERED TO SUIT INDIVIDUAL TRACTOR REQUIREMENTS

WARNING
MAXIMUM PUMP SPEED 540 R.P.M. TO AVOID PUMP DAMAGE
MINIMUM PUMP SPEED 400 R.P.M. TO AVOID PULSATION WHILST SPRAYING

WARNING
Whenever you use this sprayer it is essential to read the instructions and warnings. ALWAYS WEAR YOUR SAFETY GEAR AND BE INVOLVED!
The instructions below describe these and other items requiring your attention. It is essential to read the manual. Read the important information in full before operating the tractor. If in doubt consult your operator's manual.

CAUTION

DANGER

PRECAUTION

GOLDACRES

HAND WASH ONLY

PROBE

DRAIN ONLY



WARNING
DO NOT DISCONNECT SPRAYER FROM TRACTOR WITHOUT BOOM SUPPORTS IN POSITION

GA8701334
3PL

450
Work Ready

GA8700310
3PL 450L

WET

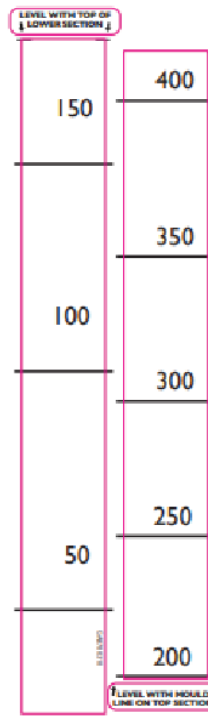



Miscellaneous Parts

PART NUMBER	DESCRIPTION	PART NUMBER	DESCRIPTION
SUCTION HOSE		LAY FLAT HOSE	
GA2000218	HOSE, SUCTION, WIRE REINFORCED, 20mm, BLACK, HOS20S, SOLD PER METER, 20M IN A ROLL	GA2000220	HOSE, SUCTION, PVC, 25mm, BLACK, HOS25PVC, SOLD PER METER, 30M IN A ROLL.
GA2000222	HOSE, SUCTION, 25mm, WIRE REINFORCED, HOS25S, SOLD PER METER, 20M IN A ROLL		
GA2000224	HOSE, SUCTION, 32mm, WIRE REINFORCED, HOS32S, SOLD PER METER, 20M IN A ROLL	HOSE CLAMPS	
GA2000226	HOSE, SUCTION, 38mm, WIRE REINFORCED, HOS38S, SOLD PER METER, 20M IN A ROLL	GA5004865	Hose Clamp, 3/8,SS (8-16/9W)
GA2000229	HOSE, SUCTION, 51mm, WIRE REINFORCED, HOS51S, SOLD PER METER, 20M IN A ROLL	GA5000469	Hose clamp, 1/2" SS 12-20/9W3
GA2000230	HOSE 63mm SUCTION (WIRE REINFORCED), HOS63S, SOLD PER METER,	GA5000999	Hose clamp, 3/4" SS (16-27/12W)
GA2000232	HOSE, SUCTION, 75mm, WIRE REINFORCED, HOS75S, SOLD PER METER, 20M IN A ROLL	GA5001681	Hose clamp, 1" SS (20-32/12W)
NOTE: SUCTION HOSE CAN BE IDENTIFIED BY ITS EXTERNAL GREEN STRIPE AND WIRE REINFORCEMENT.		GA5016813	Hose Clamp, 1 SS large (25-40/12W)
PRESSURE HOSE		GA5002783	Hose Clamp, 1 1/4, SS (30-45/13W)
GA2000200	HOSE, PRESSURE, 7mm, BLACK (250PSI), HOS7P	GA5002873	Hose Clamp, 1 1/2" SS (32-50/12W)
GA2000211	HOSE, PRESSURE, 12mm, BLACK, 250PSI, HOS13P, SOLD PER METER, ROLL = 250M	GA5003325	Hose clamp, 2 SS, (40-60/12W)
GA2000216	HOSE, PRESSURE, 20mm, BLACK 250PSI, HOS20P, SOLD PER METER, ROLL = 100M.	GA5016815	Hose Clamp, 50-70 /12 C7 W4, SS
GA2000219	HOSE, PRESSURE, 25mm, BLACK 250PSI, HOS25P, SOLD PER METER, 100M IN A ROLL.	GA5004241	Hose clamp, 60-80mm, S/S 31/2
GA2000223	HOSE, PRESSURE, 32mm BLACK (250 PSI), HOS32P, SOLD PER METER, 60M IN A ROLL.	CABLE TIES	
GA2000225	HOSE, PRESSURE, 38mm BLACK (250 PSI), HOS38P, SOLD PER METER, 20M IN A ROLL	GA5002173	Cable tie Black 100 x 2.5 [C]
NOTE: PRESSURE HOSE CAN BE IDENTIFIED BY ITS BLUE INTERNAL LAYER.		GA5003517	Cable tie black 140 x 3.5 [C]
PVC HOSE		GA5004455	Cable ties Black 190 x 4.5 mm [C]
GA2000220	HOSE, SUCTION, PVC, 25mm, BLACK, HOS25PVC, SOLD PER METER, 30M IN A ROLL.	GA5000685	Cable Tie Black 320 x 7.5mm [C]
GA2000227	HOSE, SUCTION, PVC, 40mm, BLACK, HOS40PVC, SOLD PER METER, 20M IN A ROLL	GA5000687	Cable tie, Black, 370x 4.8mm [C] 100PK
GA2000228	HOSE, PVC, 50mm, BLACK, HOS50PVC, SOLD PER METER, 20M IN A ROLL	GA5021235	Cable Tie Black 540 x 7.5mm [C]
GA2000231	HOSE, SUCTION, PVC, 75mm, BLACK, HOS75PVC, SOLD PER METER	SPIRAL GUARD	
NOTE: PVC HOSE CAN BE IDENTIFIED BY ITS RIBBED OUTER SURFACE.		GA5015669	Spiral guard, 20mm, Black
SIGHT TUBE HOSE			
GA2000209	Hose, Clear, 12mm, Sight tube, HOS12SIGHT, Sold per meter, Roll = 20M		
GA2000210	Hose, 12mm, Clear, Wire reinforced, HOS12WSIGHT, Sold per meter, Roll = 20M		

Goldacres Terms & Conditions of Sale & Warranty



1. These terms and conditions apply to all goods and/or services supplied by us to you. You are agreeing to them by placing an order with us.
 2. Unless you have a previously approved account with us you must pay us the purchase price for the goods and/or services we supply to you, together with any other applicable fees or charges immediately on delivery or collection of the goods, or if ordered online or by phone on the placement of your order. All repairs or servicing must be paid for before we will release the goods to you. If you do have an
 3. Time is of the essence for all payments required under these conditions.
- Unless specifically stated otherwise, all prices which we quote or estimate to you are inclusive of GST for goods supplied within Australia and exclusive of GST for goods exported outside of Australia. If GST is payable on a Taxable Supply made by us to you, then you must also pay the amount of GST payable in respect of that Taxable Supply as an additional payment.
5. You must pay interest on any amounts not paid by the due date at a rate 2% higher than the rate for the time being fixed under section 2 of the Penalty Interest Rates Act 1983 (Victoria) as at the date the amount became due.
 6. Property in goods supplied (and in any goods which we may have previously supplied to you) remains with us until we have been paid in full for all amounts you owe us including payment for the goods and any applicable interest, fees and charges, and until then:
 - a. you hold the goods only as a bailee and have no right to claim any other interest in the goods, including any security for any liquidated or unliquidated debt or obligation that we owe you, or any lien over the goods;
 - b. we may enter and recover possession of the goods from any site owned, possessed or controlled by you and you
 - c. you must not deliver or on-supply any of the goods (nor any document of title to them) to any person, but if you do then you hold the proceeds of the on-supply of the goods on trust for us and must pay the amount to us immediately when received;
 - d. you must not allow any person to have or acquire any security interest in the goods nor create any absolute or defeasible interest in the goods in relation to any third party except as we may authorise;
 - e. you must insure the goods for their full insurable or replaceable value (whichever is higher) and provide us with details of the insurance if we request it;
 - f. you must not remove, deface or obliterate any identifying mark or number on any of the goods;
 - g. your right to possession of the goods ceases if we recall or recover the goods, or if you become insolvent, you enter into voluntary or involuntary administration or receivership, or a petition is filed for your bankruptcy or winding up.
- You further agree:
- h. that the retention of title under this clause is a security interest within the meaning of the Personal Property Securities Act 2009 (Cth) ("PPSA");
 - i. to grant us a purchase money security interest (as that term is defined in the PPSA) in relation to the goods;
 - j. to contract out of all of your existing and future rights under the provisions referred to in paragraphs (a) through to (f) of section 115(1) of the PPSA, to the full extent permitted;
 - k. to sign any documents or do any things which we may reasonably require to enable us to register a financing statement or financing change statement on the register (as defined in the PPSA);
 - l. to pay any costs we incur in registering and maintaining a financing statement (including registering a financing change statement) and enforcing the security interest created under these terms and conditions.
7. Risk in the goods passes to you upon their delivery to or collection by you.
 8. You hereby indemnify us and our employees, directors, contractors and agents against, and release us and them from, any loss (including reasonable legal costs and expenses) or liability incurred by us and/or them arising from any claim, demand, suit, action or proceeding by any person against us and/or them where such loss or liability arose directly or indirectly from or in connection with any breach of these terms and conditions or from use of the goods and/or services unless such liability is directly caused by the negligence or default of the person indemnified.
 9. You, or anyone on your behalf must not, and you must take steps to ensure that your employees, agents and contractors do not, nor assist anyone else to:
 - a. copy, memorise, reproduce, misappropriate or reverse engineer the whole or any part of the goods
 - b. challenge, contest or oppose any of our intellectual property rights
 - c. use any name or logo associated with the goods other than as we authorise you
 - d. divulge our confidential information to any person or use it for your own benefit except as we have expressly authorised or as required by law.
 10. Any specifications, drawings, details, statistics or performance figures we may have given you about the goods and/or services are only estimates and any deviation does not entitle you to make any claim against us. Any sample is provided only to indicate the general nature of the product, and we do not warrant that goods supplied will exactly correspond with any sample or with any previous or future goods supplied.
 11. Except as stated in any separate written warranty we may provide you with the goods or a quote, under no circumstances will we have any liability to replace or repair defects in the goods where:
 - a. the defects have not arisen solely from faulty materials supplied by us or faulty workmanship by us;
 - b. the goods have received maltreatment, inattention or interference or have been used, applied, packaged or stored other than in accordance with our instructions and recommendations;
 - c. products not manufactured by or approved by us have been used with the goods.
 12. Except as provided in these conditions, all express and implied warranties guarantees and conditions under statute or general law as to merchantability, description, quality, suitability or fitness of the goods for any purpose or as to design, assembly, installation, materials or workmanship or otherwise are expressly excluded. We are not liable for physical or financial injury, loss or damage or for consequential loss or damage of any kind arising out of the application, supply, layout, assembly, installation or operation of the goods or arising out of our negligence or in any way whatsoever. The exceptions in clause (12) extend to any Third Party Accessories installed in the goods.
 13. If any condition or warranty is implied into this agreement under the Competition and Consumer Act (2010) (Cth) or any equivalent State or Territory legislation and cannot be excluded, then our liability is limited to one or more of the following:
 - a. in the case of goods, the replacement of the goods or the supply of equivalent goods, the repair of the goods, the payment of the cost of replacing the goods or of acquiring equivalent goods, or the payment of the cost of having the goods repaired;
 - b. in the case of services, the supplying of the services again, or the payment of the cost of having the services supplied again.
 14. Nothing in these conditions is to be read or applied so as to exclude, restrict or modify or have the effect of excluding, restricting or modifying any condition, warranty, guarantee, right or remedy implied by law and which by law cannot be excluded, restricted or modified.
 15. Any quotes on pricing provided by us are consistent with the prevailing market at the time of quotation, including considerations as to rates of freight, insurance, customs, duties, exchange, shipping expenses, sorting and stacking charges, cartage, cost of materials and other charges affecting the cost of production prevailing at that date.
 16. Any increases in the quote price occurring either before or during the agreement, shall be to your account.
 17. Our quotations are open for acceptance within the period stated therein. If no period is stated, our quotations are open for acceptance for (14) fourteen days from the date the quote was given.
 18. All prices listed in our quotations and product catalogue are subject to change or alteration without notice.
 19. Unless we otherwise agree in writing we accept credit card or eftpos payments only.
 20. We do not accept payment by cheque unless we have previously agreed in writing to do so.
 21. Any goods you deliver to us must be free of any chemicals. If you deliver goods that are not free of chemicals, you must pay any costs incurred by us including the cost of our own staff in removing and disposing of the chemicals and cleaning the goods.
 22. If after 28 days of notifying you that your goods are ready for delivery we have received no communication from you, we retain any rights under the Australian Consumer Law and Fair Trading Act 2012 (Vic) to sell the goods to recover the value of any outstanding debt you may owe us.
 23. You are responsible for backing up any Data that you, or your agent, may install on the goods. If the Data is wiped, corrupted, or lost, we are not liable (whether we are negligent or otherwise) for any damage that may result from that Data being wiped, corrupted or lost.
 24. Before you use any of our goods you must check, and if necessary adjust, all settings to ensure the goods are properly calibrated.
 25. We are not liable to you for any failure by us to perform any of our obligations under this agreement caused by an impediment or circumstance beyond our control.
 26. In these terms and conditions,
 - a. "we", "us" or "our" means the entity within the Goldacres Group from which you purchase goods and/or services, including, but not limited to:
 - i. Goldacres Trading Pty Ltd ACN 061 306 732; and
 - ii. Goldacres Sprayer Centre Pty Ltd ACN 639 231 520
 - b. "you" or "your" means the individual or company that purchases goods and/or services from us.
 - c. "our confidential information" includes all of our secrets, ideas, know how, concepts, information, copyright, computer programs, manuals, precedents whether in writing or in any other form and all other information relating to us or our affairs, businesses, sales, marketing or promotional information, and any information about the ingredients, mix, make-up or manufacturing process of the goods
 - d. "goods" includes any associated services except where the context does not permit.
 - e. "Third Party Accessories" includes anything incorporated in the goods that is manufactured and supplied to us by a third party.
 - f. "Data" includes any information capable of being installed and or stored on an electronic device.
 27. Used Goods- For any second hand or used Goods sold, except to the extent that a manufacturer's warranty applies.
 - a. all used or second-hand Goods are sold on an "as is where is" basis with all existing or future inadequacies, faults or defects, if any, and whether they are known or unknown.
 - b. The Seller does not warrant the second hand or used Goods are fit for any purpose or free from any defects and does not warrant the accuracy of any service or repair history, meter or hour readings and to the extent permitted by law the Buyer releases the Seller from all liability arising or connection with any defects faults or inadequacies in the Goods and any warranty under these terms or at law excludes liability for costs other than what is reasonable or customary to rectify and does not include costs for time or labour, testing, travel or freight or packaging and handling.